

SADDLE WELD DETAIL  
(TYP 4 PLACES)

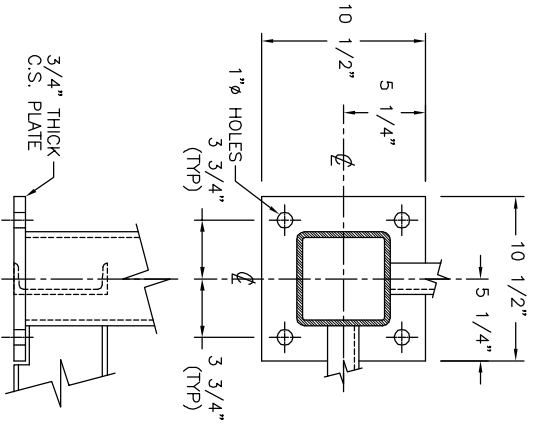

BASEPLATE DETAIL  
(TYP 4 PLACES)

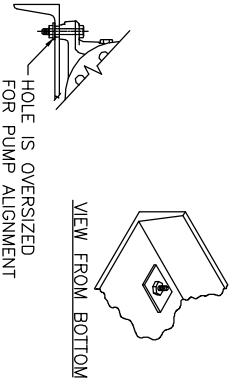

PUMP SUPPORT DETAIL

**NOTE:**  
CUSTOMER TO FIELD ALIGN PUMPS AND MOTORS, THEN SEND KCD CERTIFICATION PAPERS.

A1	INLET VALVE				NONE	
A2	CONTROL VALVE				NONE	
A3	BYPASS VALVES	2			NIBCO	T-111
A4	MAKE UP BY-PASS PIPING	2			KOD SHOP	
A5	STRAINER				NONE	
B1	STEAM PRV				NONE	
B2	STEAM CONTROLLER				NONE	
B3	BYPASS VALVES				NONE	
B4	STEAM PRV BY-PASS PIPING				NONE	
B5	1 STRAINER	3			MUELLER	752
C1	RELIEF VALVE				NONE	
C2	RELIEF VALVE PIPING				NONE	
D1	THERMOWELL				NONE	
E1	PRESSURE GAUGE				NONE	
E2	SIPHON & COCK				NONE	
E3	PRESSURE TRANS				NONE	
F1	VENT VALVE				NONE	
F2	1 ORIFICE PLATES	#/VA			#/VA	
F3	BYPASS VALVES				NONE	
F4	VENT PIPING				NONE	
G1	1 MW SPARE GASKETS				NONE	
H1	VACUUM BREAKER				NONE	
M1	BFP RECIRC SHUTTOFF					
M2	BFP RECIRC CHECK					
M3	BFP ORIFICE /VALVE					
M4	BFP PIPING				NONE	
M5	BFP PRESSURE GAUGE	4			GRUNDFOS	CR60-50U
M1	2 BOILER FEED PUMPS	4			NIBCO	F817.0
N2	2 ISOLATION VALVE	4			MUELLER	758
N3	2 STRAINER	4			KOD SHOP	
N4	2 PIPING	4				
N5	2 EXPANSION JOINT	4				
N6	BFP DISC PRESSURE GAUGE					
N7	BFP DISC CHECK					
N8	BFP DISCH ISOLATION					
O	CHEMICAL FEED QUILL				NONE	
P	1 MW SPARE GASKETS					
Q1	OVERFLOW VALVE				NONE	
Q2	CONTROL VALVE				NONE	
Q3	OVERFLOW PIPING				NONE	
R1	LEVEL SWITCHES				NONE	
R2	1 LEVEL SWITCH BRIDLE PIPING	1 1/2			NIBCO	T-111
S1	1 GAUGE GLASS				NONE	
S2	1 GAUGE GLASS BRIDLE PIPING	1 1/2			NIBCO	T-111
T1						
2	CONTROL PANEL					
	STARTERS				NONE	
1	PUMP STAND				14.2	

THIS DOCUMENT AND THE INFORMATION IT CONTAINS HAVE BEEN FURNISHED FOR USE BY YOUR OWN ORGANIZATION ONLY AND FOR PURPOSE CONSISTENT WITH THE TRANSACTION BETWEEN YOUR ORGANIZATION AND KANSAS CITY DEAERATOR COMPANY. NO COPIES OF OR DATA FROM THIS DOCUMENT SHALL BE FURNISHED TO ANY THIRD PARTY WITHOUT THE WRITTEN AGREEMENT OF KANSAS CITY DEAERATOR CO., OVERLAND PARK, KANSAS 66209

NO.	DATE	DESCRIPTION OF CHANGE	BY

CLIENT: **KANSAS CITY DEAERATOR CO.**  
6731 W. 121st STREET  
OVERLAND PARK, KANSAS 66209  
(913) 338-2111 FAX (913) 338-2144

DWG. NO.: **TCP149-6016-cr64-3**  
MODEL: TCP149  
TITLE: **GENERAL ARRANGEMENT PACKAGE - TCP6016**

JOB #	SCALE	DESIGNED	DRAWN	CHECKED	DATE	UTD
STD	NTS	MK	GENI	PC	06-10-06-10 2004	2004