

FRONT VIEW

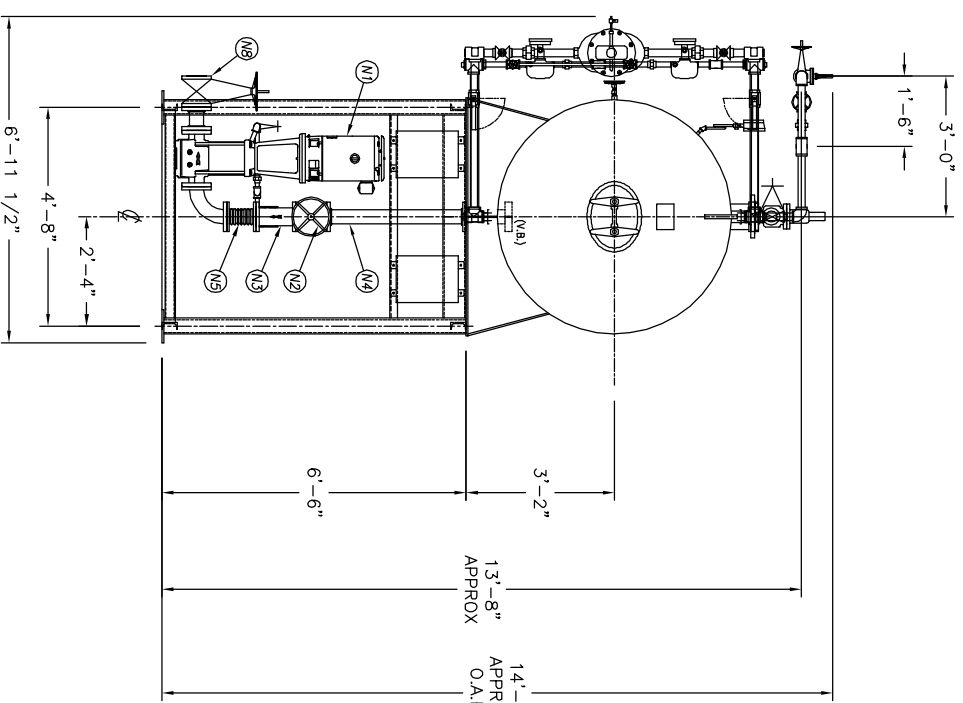

END VIEW

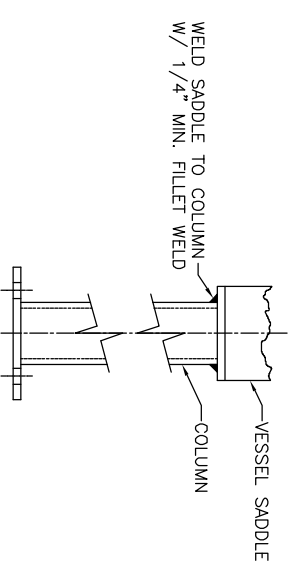

SADDLE WELD DETAIL  
(TYP 4 PLACES)

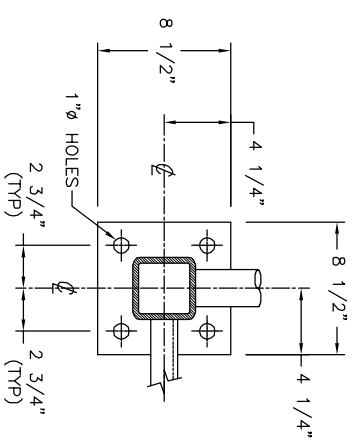

BASEPLATE DETAIL  
(TYP 4 PLACES)

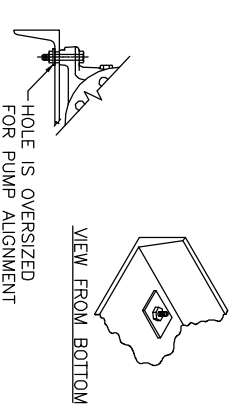

PUMP SUPPORT DETAIL

A1	INLET VALVE			NONE	
A2	CONTROLLER			NONE	
A3	3 BYPASS VALVES	2		NIBCO	T-111
A4	1 MAKE UP BY-PASS PIPING	2		KCD SHOP	
A5	STRAINER			NONE	
B1	STEAM PRV			NONE	
B2	STEAM CONTROLLER			NONE	
B3	BYPASS VALVES			NONE	
B4	STEAM PRV BY-PASS PIPING	3		MELLER	782
B5	1 STRAINER			NONE	
C1	RELIEF VALVE			NONE	
C2	RELIEF VALVE PIPING			NONE	
D1	THERMOWELL			NONE	
E1	PRESSURE GAUGE			NONE	
E2	SIPHON & COCK			NONE	
E3	PRESSURE TRANS			NONE	
F1	VENT VALVE			NONE	
F2	1 ORIFICE PLATES	#N/A		#N/A	
F3	BYPASS VALVES			NONE	
F4	VENT PIPING			NONE	
G1	HW SPARE GASKETS			NONE	
H1	VACUUM BREAKER			NONE	
M1	BFP REGICR SHUTOFF				
M2	BFP REGICR CHECK				
M3	BFP ORIFICE / VALVE				
M4	BFP PIPING			NONE	
M5	BFP PRESSURE GAUGE	4		GRUNDFOS	CR80-50U
N1	2 BOILER FEED PUMPS	4		NIBCO	FB17-0
N2	2 ISOLATION VALVE	4		MELLER	788
N3	2 STRAINER	4		KCD SHOP	
N4	2 PIPING	4			
N5	2 EXPANSION JOINT	4			
N6	BFP DISC PRESSURE GAUGE				
N7	BFP DISC CHECK				
N8	BFP DISCH ISOLATION				
O	CHEMICAL FEED QUILL			NONE	
P	HW SPARE GASKETS			NONE	
Q1	OVERFLOW VALVE			NONE	
Q2	CONTROLLER			NONE	
Q3	OVERFLOW PIPING			NONE	
R1	LEVEL SWITCHES	1 1/2		NIBCO	T-111
R2	LEVEL SWITCH BRIDLE PIPING	1 1/2		NONE	
S1	GAUGE GLASS	1 1/2		NONE	
S2	1 GAUGE GLASS BRIDLE PIPING	1 1/2		NIBCO	T-111
T1					
2	CONTROL PANEL STARTERS		NONE		
1	PUMP STAND		14.2		

**NOTE:**  
CUSTOMER TO FIELD ALIGN PUMPS AND MOTORS, THEN SEND KCD CERTIFICATION PAPERS.

THIS DOCUMENT AND THE INFORMATION IT CONTAINS HAVE BEEN FURNISHED FOR USE BY YOUR OWN ORGANIZATION ONLY AND FOR PURPOSE CONSISTENT WITH THE TRANSACTIONS BETWEEN YOUR ORGANIZATION AND KANSAS CITY DEAERATOR COMPANY. NO COPIES OF OR DATA FROM THIS DOCUMENT SHALL BE FURNISHED TO ANY THIRD PARTY WITHOUT THE WRITTEN AGREEMENT OF KANSAS CITY DEAERATOR CO., OVERLAND PARK, KANSAS 66209

NO.	DATE	DESCRIPTION OF CHANGE
-	-	-
-	-	-
-	-	-
-	-	-

CLIENT:



**KANSAS CITY DEAERATOR CO.**  
6731 W. 121st STREET  
OVERLAND PARK, KANSAS 66209  
(913) 338-2111 FAX (913) 338-2144

TITLE: **GENERAL ARRANGEMENT PACKAGE - HS5008**

MODEL: HS5008-065-CR45-3

DWG. NO.: **HS5008-065-CR45-3**

JOB #	SCALE	DESIGNED	DRAWN	CHECKED	DATE	UTD
STD	NTS	MK	GENI	PC	8-14 2003	8-14 2003